



04/2010 -

DACIA DUSTER 2/4 WD

Cat. No. **G/005**

e20

e20*94/20*1480*00

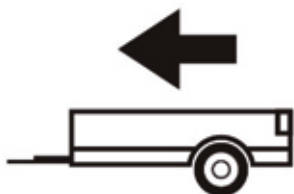

1500Kg



75Kg

D = 9,00kN

D (kN) =



MAX kg

x

MAX kg

x 0,00981



MAX kg

+

MAX kg



IMIOLA HAK-POL

96-111 KOWIESY, CHOJNATA 23A, POLAND

tel. +48 46 831 73 31, fax +48 831 74 29

e-mail: office@imiola.pl, www.imiola.pl

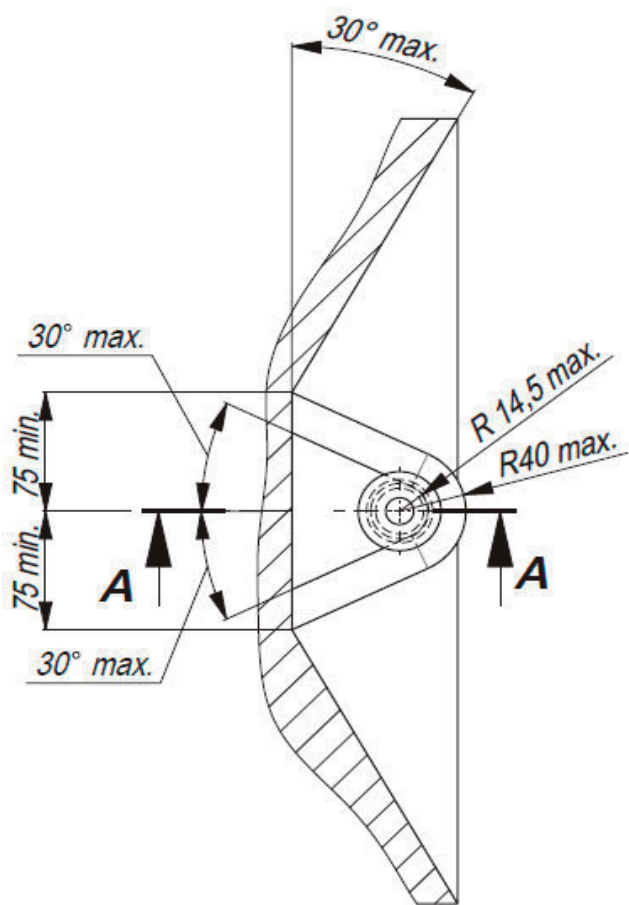

PRZEKRÓJ A-A

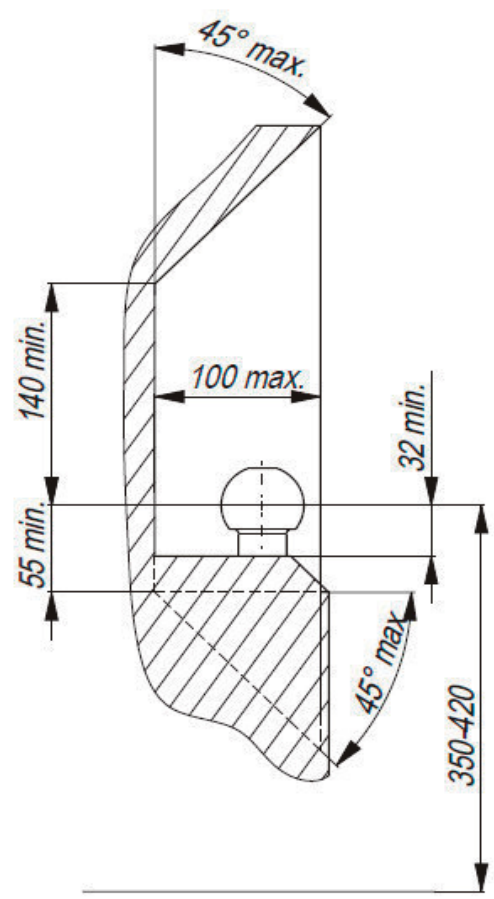

PL Należy zagwarantować przestrzeń swobodną według załącznika VII, rysunek 25a/b Regulaminu EKG ONZ 55.01 przy dopuszczalnym ciężarze całkowitym pojazdu.

F L'espace libre doit être garanti conformément à l'annexe VII, illustration de la réglementation 55.01 CE pour un poids total en charge autorisé du véhicule.

GB The clearance specified in appendix VII, diagram 25a/b of Regulation No. 55.01 UN EU must be guaranteed at laden weight of the vehicle.

D Der Freiraum nach Anhang VII, Abbildung 25a/b der Vorschriften 55.01 EG ist zu gew 25a/bahrleisten bei zulässigem Gesamtgewicht des Fahrzeuges

Moment skrecający dla śrub i nakrętek (8.8) Torque settings for nuts and bolts (8.8)	
M8	25Nm
M10	55Nm
M12	85Nm
M14	135Nm
M16	195Nm

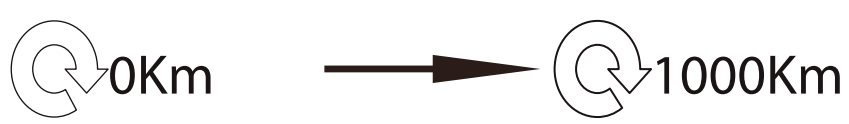

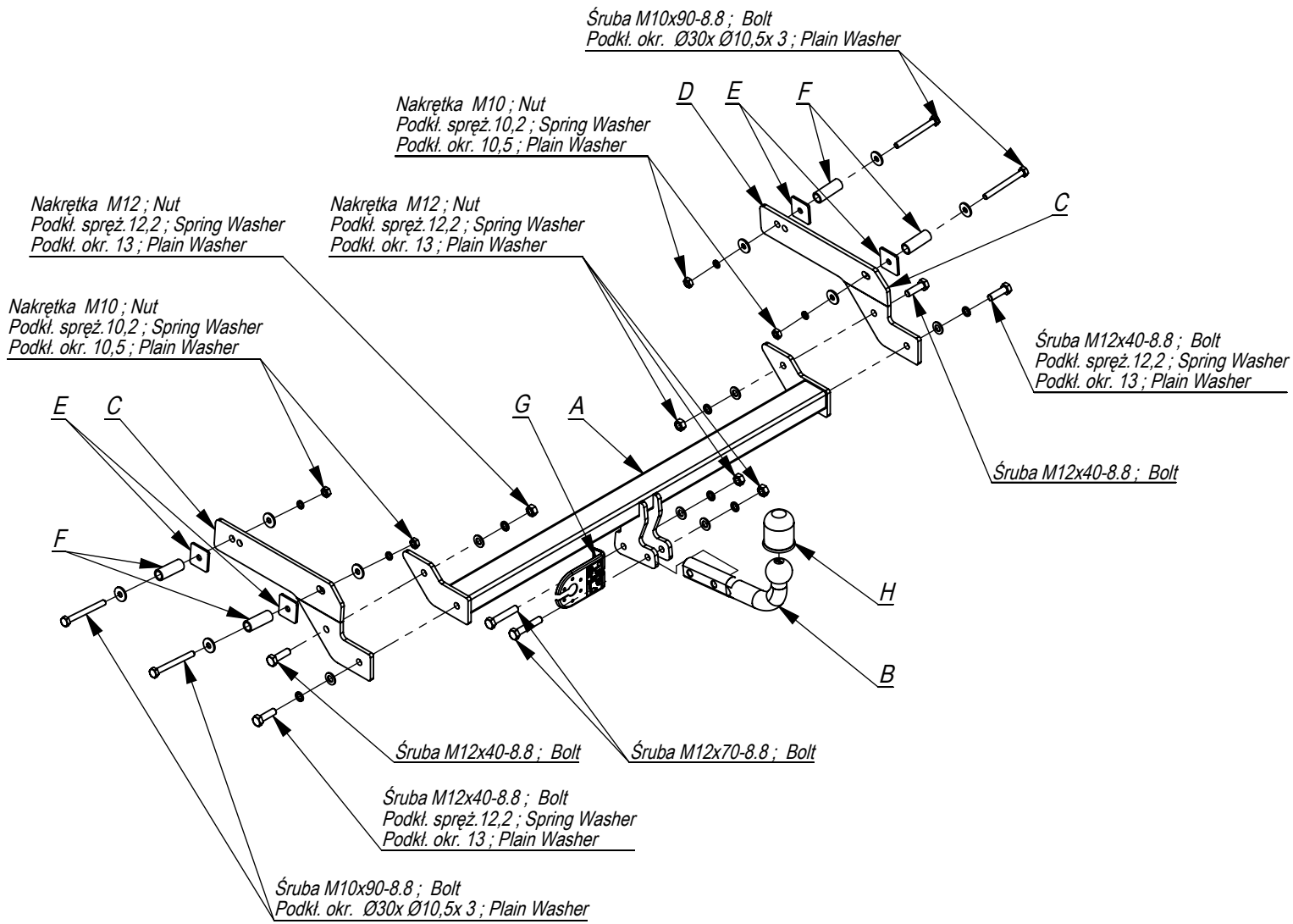

	A	x1		M12x70	2
	B	x1		M12x40	4
	C	x1		M10x90	4
	D	x1		Ø30xØ10,5x3	4
	E	x4		13	6
	F	x4		10,5	4
	G	x1		12,2	6
	H	x1		10,2	4

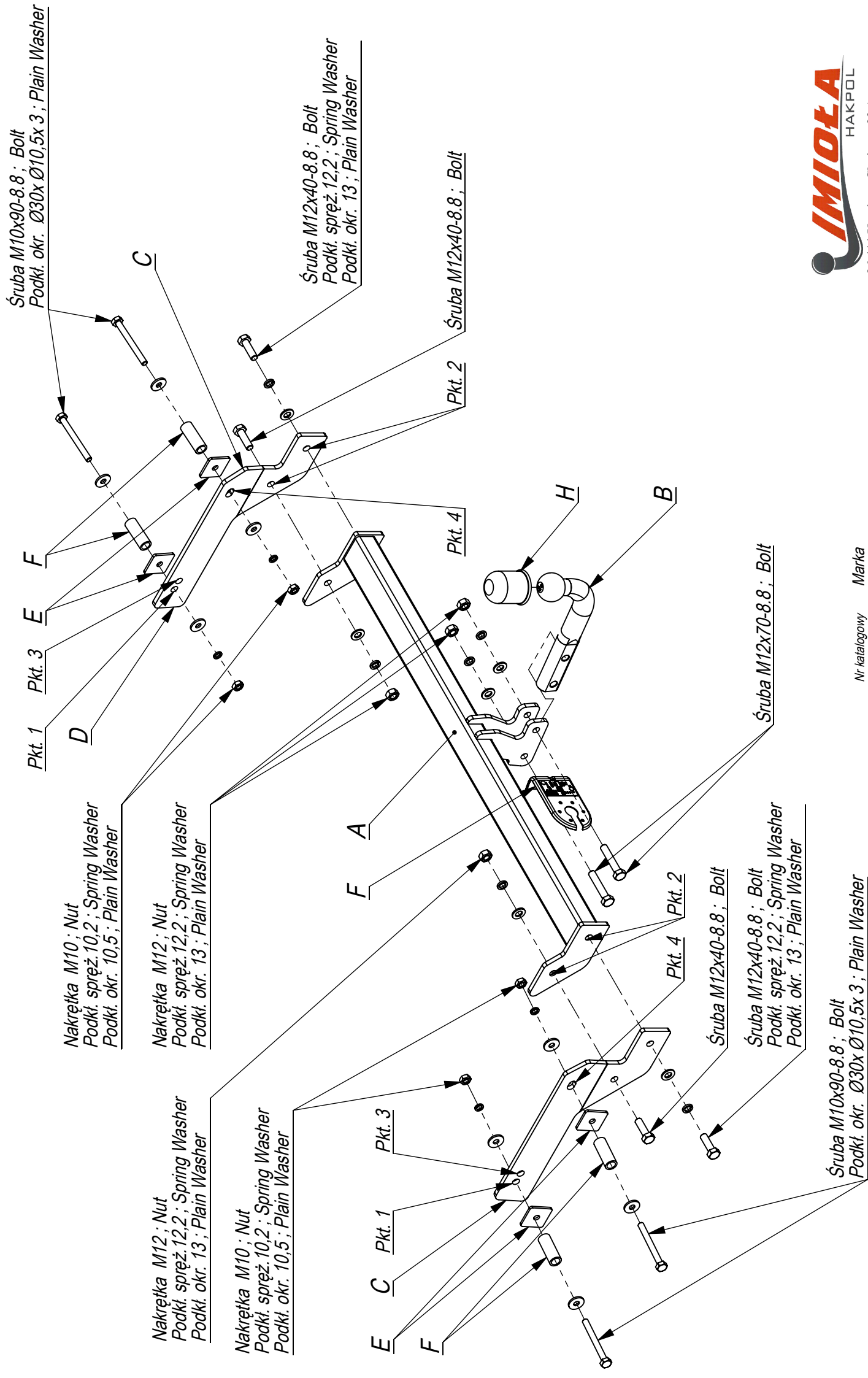

- W technologiczne otwory w podłużnicach włożyć tuleje dystansowe.
- Elementy zaczepu C przykręcić do podłużnic śrubami M10x90 8.8 (pkt 1).
- Do elementów C przykręcić belkę zaczepu A śrubami M12x45 8.8 (pkt 2).
- Dokręcić wszystkie śruby z momentem wg tabeli
- Przykręcić kulę i blachę gniazda elektrycznego.
- Podłączyć instalację elektryczną

- Unscrew the spare wheel.
- Insert distance sleeves in the technological holes of the metal clamps.
- Screw slightly elements C to the metal clamps with bolts M10x90 8.8 (point 1).
- Screw the elements C to the main bar A with bolts M12x45 8.8 (point 2).
- Tighten all the bolts according to the torque setting- see the table.
- Fix the ball and electric plate with bolts M12x70 8.8 (point 3).
- Connect the electric wires.
- Assemble the spare wheel.

- Desserrer la roue de secours,
- Placer les douilles d'écartement dans les ouvertures de longerons,
- Serrez légèrement les éléments de Rochet C aux longerons par les boulons M10x90 8.8 (point 1).
- Serrew les éléments du crochet C au socle du Rochet A par les boulons M12x45 8.8 (point 2).
- Serrer tous les boulons avec un couple de serrage selon tableau,
- Visser le crochet d'attelage et socle de prise électrique par les boulons M12x70 8.8 (point 3).
- Raccorder le circuit électrique.
- Desserrer la roue de secours.

